

SYMBOL

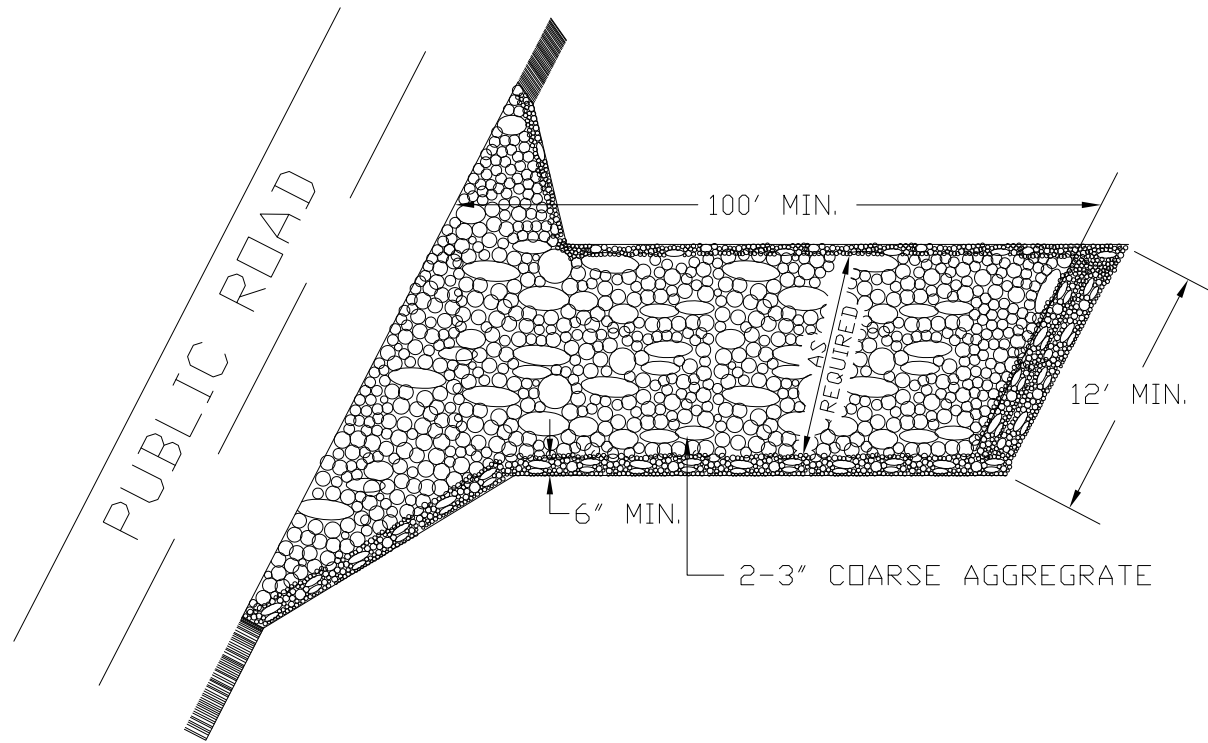
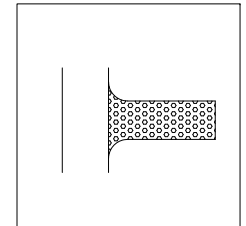

CONDITIONS WHERE PRACTICE APPLIES

Whenever traffic will be leaving a construction site and moving directly onto a public road or other paved off-site area. Construction plans should limit traffic to properly constructed entrances.

CONSTRUCTION SPECIFICATIONS

DESIGN CRITERIA

Aggregate Size-Use 2-3 inch washed stone.

Dimensions of gravel pad-

Thickness: 6 inches minimum

Width: 12-ft minimum or full width at all points of the vehicular entrance and exit area, whichever is greater

Length: 100-ft minimum

Location-Locate construction entrances and exists to limit sediment from leaving the site and to provide for maximum utility by all construction vehicles. Avoid steep grades and entrances at curves in public roads.

Washing-If conditions at the site are such that most of the mud and sediment are not removed by vehicles traveling over the gravel, the tires should be washed. Washing should be done on an area stabilized with crushed stone that drains into a sediment trap or other suitable disposal area. A wash rack may also be used to make washing more convenient and effective.

MAINTENANCE

1. Clear the entrance and exit area of all vegetation, roots, and other objectionable material and properly grade it.
2. Place the gravel to the specific grade and dimensions shown on the plans, and smooth it.
3. Provide drainage to carry water to a sediment trap or other suitable outlet.
4. Use geotextile fabrics because they improve stability of the foundation in locations subject to seepage or high water table.

Maintain the gravel pad in a condition to prevent mud or sediment from leaving the construction site. This may require periodic topdressing with 2-inch stone. After each rainfall, inspect any structure used to trap sediment and clean it out as necessary. Immediately remove all objectionable materials spilled, washed, or tracked onto public roadways.

GRAVEL CONSTRUCTION ENTRANCE

CITY OF ROCKY MOUNT
DEPT. OF ENGINEERING

APPROVED

-

DATE

09-22-2010

STD. NO.

3.17

REVISION

-

REVISIONS

NO	DATE	DESCRIPTION