

REINFORCED CONCRETE PIER DETAIL

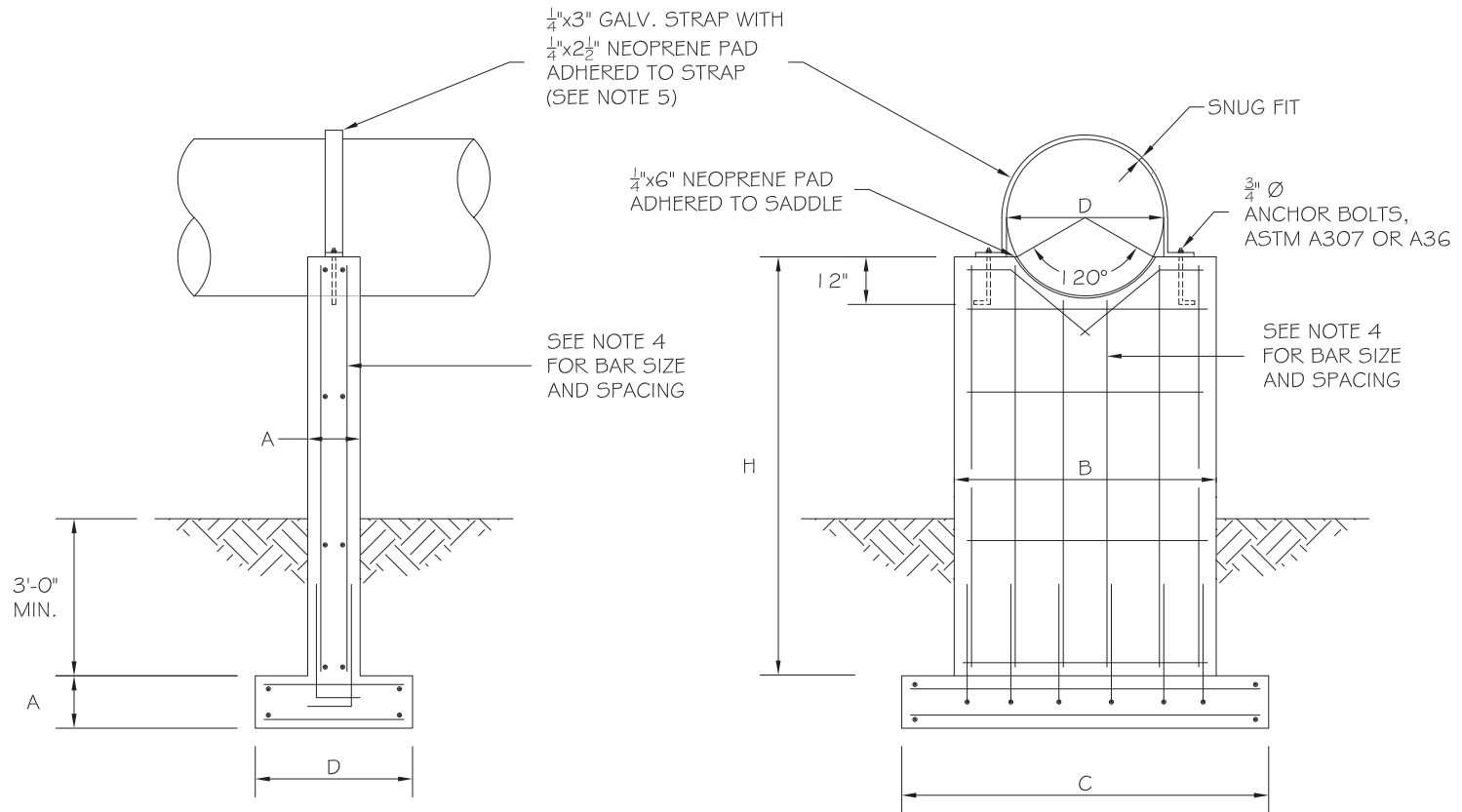

NOTE: REFER TO (SHEET 4 OF 8) FOR DIMENSIONS AND CONSTRUCTION NOTES

DATE: OCTOBER 2014	STANDARD #: 4.26
APPROVED:	SHEET # 1 OF 1
	REVISION: